

Pyxis[®]

ST-765SS-SO3 Sulfite Sensor

Sulfite + pH + Temperature Sensor



Pyxis Lab[®] Inc.

1729 Majestic Dr. (Suite 5)
Lafayette, CO 80026
www.pyxis-lab.com

V1.08

USER MANUAL

Table of Contents

1. Introducing the Pyxis ST-765SS-SO3 Sensor	3
1.2 Specifications.....	4
1.3 Unpacking the Pyxis ST-765SS	4
1.4 Standard Accessories.....	5
1.5 Optional Accessories.....	5
2. Dimension & Installation	6
3. Quick 4-20mA Start Up	9
4. Calibration and Diagnosis	10
4.1 Calibration and Diagnosis by uPyxis Mobile App	10
4.1.1 Sulfite Calibration.....	12
4.1.2 pH Calibration	13
4.1.3 4-20mA Span.....	14
4.1.4 Diagnosis	14
4.2 Calibration and Diagnosis by uPyxis Desktop App	15
4.2.1 Sulfite Calibration.....	18
4.2.2 pH Calibration	18
4.2.3 4-20mA Span.....	20
5. Calibration on the Controller	21
6. Modbus RTU	21
7. Sensor Cleaning and Maintenance	22
7.1 Other Common Troubleshooting Issues	22
8. Replacing pH and Deoxidizer Electrode Head	23
9. Contact Us	24

Warranty Information

Confidentiality

The information contained in this manual may be confidential and proprietary and is the property of Pyxis Lab, Inc. Information disclosed herein shall not be used to manufacture, construct, or otherwise reproduce the goods described. Information disclosed herein shall not be disclosed to others or made public in any manner without the express written consent of Pyxis Lab, Inc.

Standard Limited Warranty

Pyxis Lab warrants its products for defects in materials and workmanship. Pyxis Lab will, at its option, repair or replace instrument components that prove to be defective with new or remanufactured components (i.e., equivalent to new). The warranty set forth is exclusive and no other warranty, whether written or oral, is expressed or implied.

Warranty Term

The Pyxis warranty term for the ST-765SS Series sensor body is thirteen (13) months from original shipment from Pyxis. The Pyxis warranty term for the EH-765 (electrode reference head) installed on the ST-765SS Series sensor body is six (6) months from original shipment from Pyxis. In no event shall the standard limited warranty coverage extend beyond this timeline from original shipment date.

Warranty Service

Damaged or dysfunctional instruments may be returned to Pyxis for repair or replacement. In some instances, replacement instruments may be available for short duration loan or lease.

Pyxis warrants that any labor services provided shall conform to the reasonable standards of technical competency and performance effective at the time of delivery. All service interventions are to be reviewed and authorized as correct and complete at the completion of the service by a customer representative, or designate. Pyxis warrants these services for 30 days after the authorization and will correct any qualifying deficiency in labor provided that the labor service deficiency is exactly related to the originating event. No other remedy, other than the provision of labor services, may be applicable.

Repair components (parts and materials), but not consumables, provided during a repair, or purchased individually, are warranted for 90 days ex-works for materials and workmanship. In no event will the incorporation of a warranted repair component into an instrument extend the whole instrument's warranty beyond its original term.

Warranty Shipping

A Repair Material Authorization (RMA) Number must be obtained from Pyxis Technical Support before any product can be returned to the factory. Pyxis will pay freight charges to ship replacement or repaired products to the customer. The customer shall pay freight charges for returning products to Pyxis. Any product returned to the factory without an RA number will be returned to the customer. To receive an RMA you can generate a request on our website at <https://pyxis-lab.com/request-tech-support/>.

Pyxis Technical Support

Contact Pyxis Technical Support at +1 (866) 203-8397, service@pyxis-lab.com or by filling out a request for support at <https://pyxis-lab.com/request-tech-support/>.

1. Introducing the Pyxis ST-765SS-SO3 Sensor

Description

The Pyxis ST-765SS-SO3 is a stainless-steel multi-parameter membrane-less sensor based on unique electrochemical principles to determine Sulfite plus pH and temperature of water. This sensor incorporates Pyxis' advanced technology in the field of bare-gold electrochemical detection. The ST-765SS-SO3 can simultaneously compensate for temperature and pH in the measurement of Sulfite based on real-time conditions present in the application of use. This unique internal compensation results in a highly accurate sulfite measurement consistent with wet chemistry methodology commonly used for measurement of oxygen or oxidizer scavengers.

The ST-765SS-SO3 sensor offers a replaceable, front loading reference electrode assembly that has been independently developed by Pyxis Lab eliminating the shortcomings associated with membranes and gel replacement while offering reduced polarization time on startup with an electrode life span potential of up to 2-years. The flat front-end design of the ST-765SS-SO3 makes this platform less prone to contamination or fouling and is easy to clean. The ST-765SS-SO3 sensor body is composed of 304 stainless steel and is well suited for aggressive environments.

The ST-765SS-SO3 sensor offers 2x 4-20mA and RS-485 Modbus outputs and is Bluetooth 5.0 enabled when used in conjunction with the MA-CR Bluetooth Adapter. This four-electrode composite sensor provides three measured parameters including Sulfite, pH and temperature with one sensor equipped with fully integrated 2x 4-20mA and RS-485 Modbus outputs. ST-765SS-SO3 is uniquely designed for rapid and precise monitoring of oxygen or oxidizer scavengers in water and process related applications.



ST-765SS-SO3
Sulfite + pH Sensor

Key Features

- Real-Time pH + Sulfite (0-5ppm) Detection (*uPyxis Adjustable to 100ppm Max*)
- Dual 4-20mA Outputs (Sulfite + pH) and RS-485
- Bluetooth Enabled when used with MA-CR Adapter Wireless uPyxis Calibration
- Integrated RTD & pH Compensation to pH 9.0+ of the Sulfite Value
- Replaceable EH-765 Reference Electrode Assembly – Simple Maintenance

Common Applications

- RO Feedwater Chlorine Removal
- Wastewater Effluent Chlorine Removal (*when used with FR-300-PLUS*)
- Boiler Feedwater & Blowdown Oxygen Scavenger Monitoring



EH-765
Replacement Electrode
for all ST-765SS Series

1.2 Specifications

Item	ST-765SS-SO3
P/N	53624
Sensor Body Material	304SS
Sulfite Standard Range	0.00-5.00 ppm Sulfite <i>(Factory Standard Range – Adjustable via uPyxis)</i>
Sulfite Precision	± 0.01mg/L or 1% of the value w/pH compensation up to 9.0+
Sulfite Maximum Range	0-100 ppm Sulfite <i>(Adjustable via uPyxis 4-20mA SPAN ADJUST)</i>
Sulfite Maximum Precision	± 1 mg/L or 1% when in MAX SPAN Mode
pH Range	0-14
pH Precision	±0.01 pH
Sample Inlet Pressure	7.25 – 30 psi (0.05 – 0.2MPa)
Installation	ST-007 Stainless Steel Flow Cell Assembly <i>(Sold Separately)</i>
ST-007 Minimum Flow Rate	200 mL/minute
ST-007 Maximum Flow Rate	400 mL/minute
ST-007 Sample Inlet	¼ - inch OD
ST-007 Sample Outlet	¼ - inch OD
Power Supply	22 – 26VDC, Power Consumption 2W
Storage Temperature	-7 °C – 60 °C (20 – 140 °F)
Outputs	Dual Isolated 4 – 20 mA Analog Outputs + Isolated RS-485 Digital Output
Dimension (L x D)	Length 8.3 inch (210.8 mm), body diameter 1.4 Inch (35.6 mm)
Weight	530 g (1.16lbs)
Maximum Sensor Pressure	100 psi (6.9 Bar) – Sensor Only
Operating Temperature	4 °C – 49 °C (40 – 120 °F)
Wet Material	UPVC
Rating	IP67, Fully Dustproof & Waterproof
Selectivity	Non-Selective / Cross Sensitive to other Reducing Species
Compliance	EPA 334.0 / ISO 7393
Regulation	CE Marked / RoHS
Cables Included	MA-4.9CR Cable (8Pin Adapter – 4.9ft) MA-1.5CR Cable (8 Pin Adapter / Flying Leads – 1.5ft)
Typical Electrode Service Life	2 Years
Electrode Warranty	6 Months
Sensor Body Warranty	13 Months

NOTE Specifications are subject to change without notice.

1.3 Unpacking the Pyxis ST-765SS

Remove the instrument and accessories from the shipping container and inspect each item for any damage that may have occurred during shipping. Verify that all items listed on the packing slip are included. If any items are missing or damaged, please contact Pyxis Customer Service at service@pyxis-lab.com

1.4 Standard Accessories

- One **ST-765SS-SO3** sensor (P/N: 53624)
 - **NOTE-** *The ST-007 Flow Tee Assembly must be purchased separately see below*
- One **MA.4.9CR** – (Standard Cable Male-Female 8-Pin Adapters – 4.9ft)
- One **MA-1.5CR** – (Flying Lead Cable Female/Flying Lead 8-Pin Adapter – 1.5ft)
- The full instrument manual is available for download at [Support Documents - Pyxis Lab, Inc. \(pyxis-lab.com\)](https://www.pyxis-lab.com/support-documents)

1.5 Optional Accessories

The following optional accessories can be purchased separately via your preferred Pyxis Lab distributor or Pyxis Customer Service at order@pyxis-lab.com.

Accessory Name	Item number
ST-007 <i>(316L Stainless Steel Tee Assembly ¼-inch OD Compression)</i>	50700-A51
EH-765 <i>(Replacement Reference Electrode Head for ST-765SS Series)</i>	53601
MA-CR <i>(Bluetooth Adapter For use with Pyxis 8-Pin Sensors)</i>	MA-CR
MA-NEB <i>(USB Bluetooth Adapter for use with Laptop or Desktop for uPyxis)</i>	MA-NEB
UC-80 <i>(Display + Data Logging Terminal)</i>	14003
MA-50CR <i>(Extension Cable-50 feet)</i>	50743
pH4-7-10 Combination Pack - Reference Standard Solutions <i>(500mL/each)</i>	57007
SP-200 OxiPocket <i>(Pocket All-Oxidizing Disinfectants Colorimeter & Fluorometer)</i>	50802

2. Dimension & Installation

The ST-765SS-SO3 should be installed in the ST-007 stainless steel inline sensor tee assembly for optimum accuracy. Sulfite functions as an oxygen and chlorine scavenger are highly susceptible to rapid degradation. Stainless steel is recommended to ensure minimal sulfite depletion between injection of treatment and the sensor. The ST-007 is provided with ¼-inch stainless steel OD inlet and outlet compression adapter (SwageLok) and it is recommended that ¼-inch OD stainless steel tubing be utilized for sample flow. The recommended flow rate for the ST-765SS-SO3 sensor in the ST-007 inline tee assembly is 200-400mL per minute and should be controlled upstream with rotameter. The inlet water sample pressure should be maintained between 7.5 and 30 psi with discharge to open drain or atmospheric sump.

ST-765SS-SO3 Dimensions (mm)

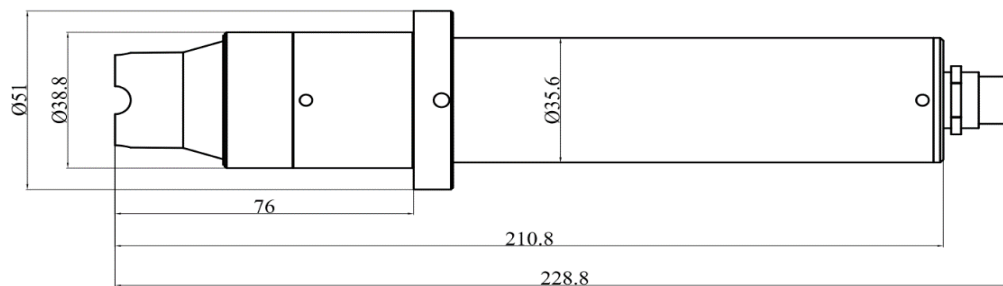

Figure 1. Dimension of the ST-765SS (mm)

ST-007 Flow Cell Dimensions (mm)

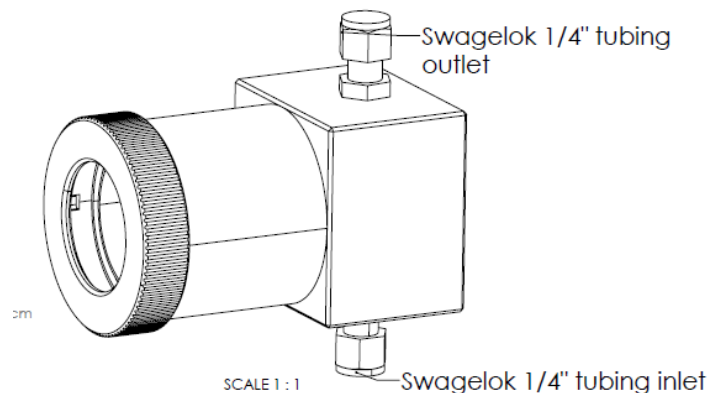

Figure 2. ST-007 Flow Cell Dimensions for ST-765SS Series Sensors

IK-765SS-SO3 Sulfite + pH + Temperature Online Monitoring Panel as shown in Figure 3.

The IK-765SS-SO3 is a pre-assembled Sulfite + pH + Temperature monitoring panel consisting of the ST-765SS-SO3 (Sulfite) sensor with mounted ST-007 stainless steel flow cell with rotameter and hall effect flow meter, connected to the UC-80 Display + Data Logging Terminal. These platform solutions offer real-time display, data logging and signal output capability of sample Sulfite, pH and temperature. The UC-80 is a microprocessor display/data-logging terminal that has been preconfigured to connect Pyxis inline sensors with fully integrated calibration, scaling and measurement protocol. When any Pyxis Lab sensor is connected to the UC-80 in RS-485 Modbus, the UC-80 automatically recognizes the sensor and configuration for immediate data display, data logging and communication. The user may also configure and calibrate the output signal through the UC-80 controller's screen. ***NOTE*** For boiler feedwater and blowdown sulfite measurement, the IK-765SS-SO3 panel must be installed downstream of a sample cooler.

Item	P/N	Description
IK-765SS-SO3	42163	ST-765SS-SO3 Sensor + ST-007 Flow Cell + UC-80 Display/Data Logger

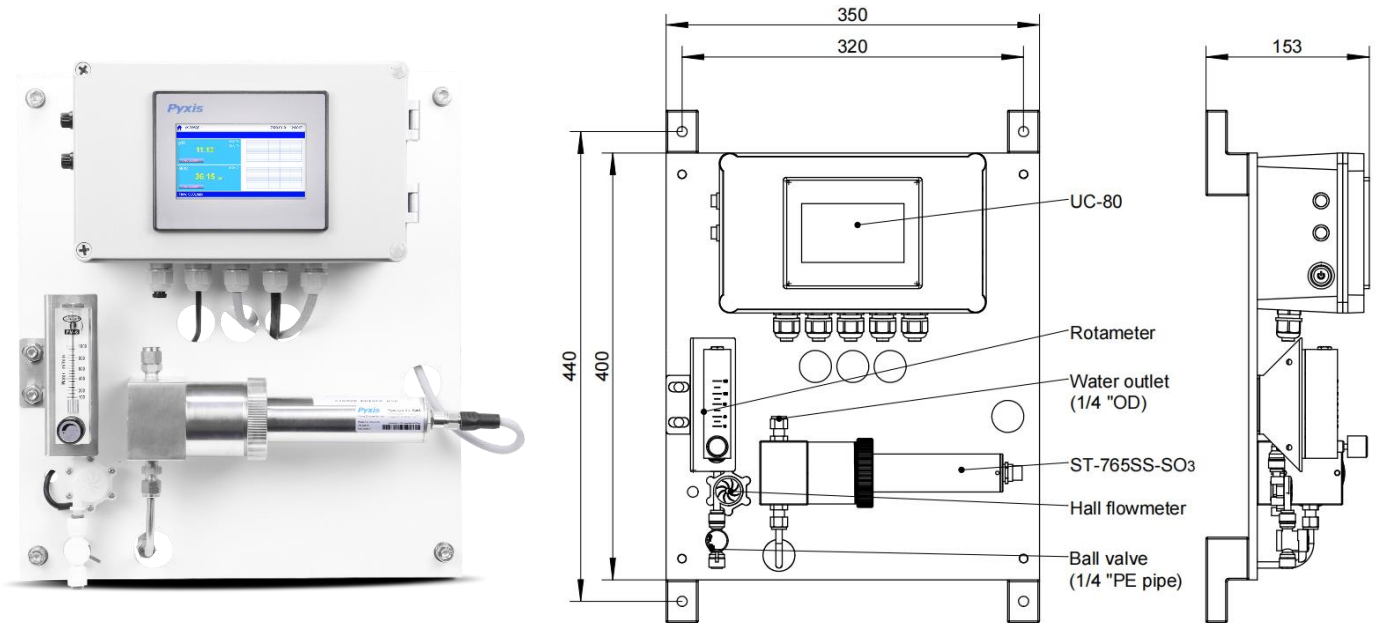
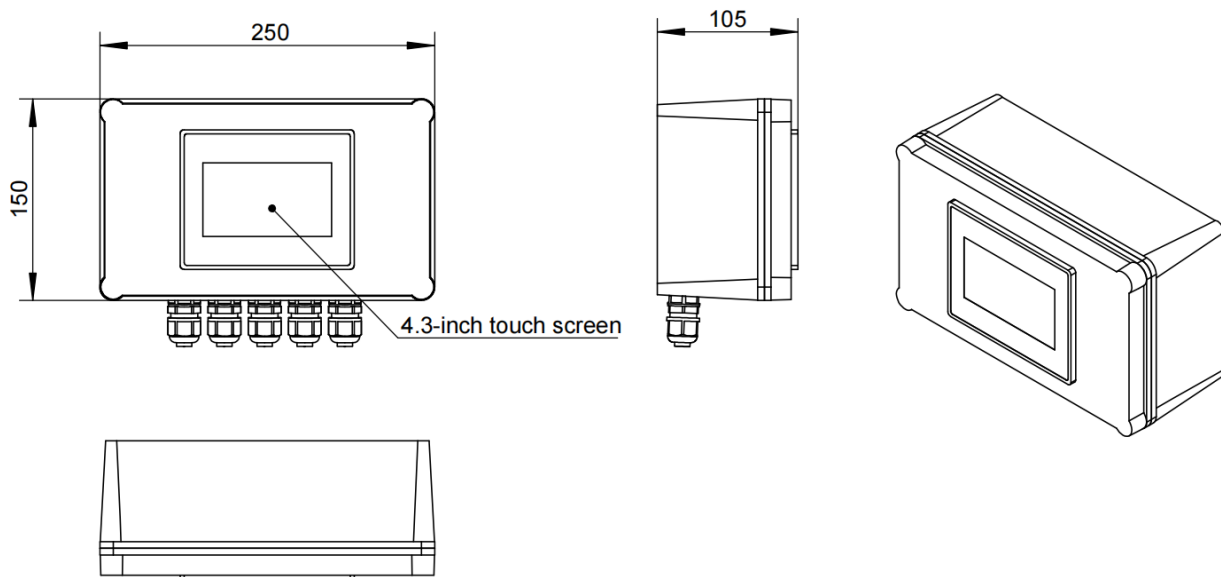

Figure 3 IK-765SS-SO3 Panel (mm)

Specifications of UC-80 Display/Data Logging Terminal

Item	UC-80
P/N	14003
Measurement Interval	Continuous Measurement
Display	4.3-inch LCD Color Industrial Capacitive Touch Screen
Storage Capacity	Built-In 128MB of Ram for Storing up to 1-Million Data/Event Records
Power Requirement	96-260VAC / 50-60 Hz; 200 W
Output	2 x 4-20 mA / RS-485 Modbus - RTU / Modbus TCP
Input	RS-485 Modbus - RTU
USB	1 x USB host, for data downloading and screen upgrade
Internet	RJ-45 socket, Modbus-TCP – For Pyxis CloudLink™
Panel Operational Temperature	40 – 113°F (4-45 °C)
Storage Temperature	Instrument: -4 – 131°F (-20 – 55°C)
Sample Water Temperature	40 – 104°F (4-40°C)
Rating	IP-65 Panel-Display
Regulation	CE / RoHS
Relative Humidity	20% - 90% (No Condensation)
Altitude	<6,561 feet (<2,000 Meter)
Dimensions (HxWxD)	H250×W150×D100mm
Approximate Product Weight	~ 5 kg

Dimensions of UC-80 (mm/in)



3. Quick 4-20mA Start Up

Follow the wiring table below to connect the ST-765SS series sensor to a controller. ***NOTE*** The ST-765SS-SO3 sensor comes preset at 0-5ppm range of measurement and output signal from the Pyxis factory. This may be altered to a maximum of 100ppm using the 4-20mA SPAN ADJUST feature with the uPyxis APP.

Wire Color	Designation
Red	24 V +
Brown	Power Ground
Green	Shield, solution ground
Gray	4-20 mA -
White	4-20 mA+ for Sulfite
Pink	4-20 mA + for pH
Blue	RS-485 A
Yellow	RS-485 B
Black	Shield, solution ground

NOTE Pyxis recommends the 24VDC power supply to the ST-765 series sensor be turned OFF for systems that experience extended periods of stagnant water conditions exceeding one hour in duration. Upon sensor power-up, the ST-765 series will complete a 5-minute electrode initialization to remove any oxide layer from the gold electrode which accumulates during stagnation. The sensor will output 1mA for oxidizer/reducer during this initialization process and return to its normal reading with 4-20mA output once complete.

ST-765SS-SO3 Sensor 4-20mA Scaling		
Unit of Measure	4mA Value	20mA Value
pH	0.00 pH	14.00 pH
Sulfite	0.00 ppm	5.00 ppm (Adjustable to 100ppm MAX)

NOTE If the 24V power ground and the 4-20 mA-return in the controller are internally connected (non-isolated 4-20mA input), it is unnecessary to connect the 4-20 mA- (Gray wire) to the 4-20 mA negative terminal in the controller. If a separate DC power supplier other than that from the controller is used, make sure that the output from the power supply is rated for 22-26 VDC @ 85mA.

4. Calibration and Diagnosis

The ST-765SS Series sensors are rigorously calibrated before leaving the factory. As such, users do not need to calibrate the sensor for a period of three months or up to one year if the sensor is maintained in clean condition. Users can however calibrate the sensor according to their application needs and as desired using the MA-CR Bluetooth adapter and uPyxis APP for mobile or desktop devices.

4.1 Calibration and Diagnosis by uPyxis Mobile App

Connect and power the ST-765SS sensor using the MA-CR Pyxis Bluetooth adapter (P/N: MA-CR) as shown in the following connection diagram. The power should be sourced from a 24 VDC power terminal of a controller. If a controller is not available, please purchase a 24VDC power supply.



MA-CR Bluetooth Adapter

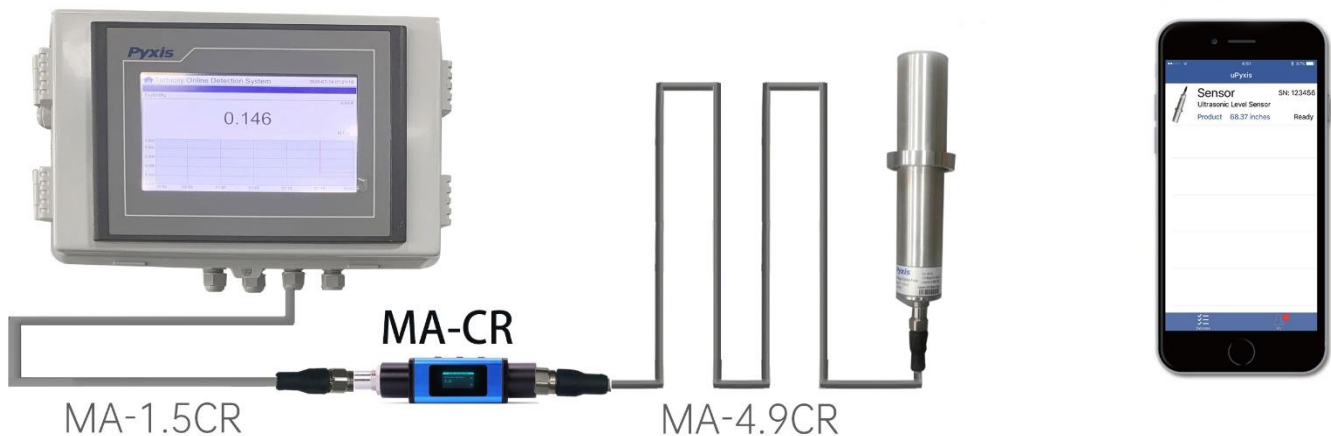

Figure 4. - Power the ST-765SS and MA-CR via USB



Download and install the uPyxis app from **Apple iStore** or **Google Play**. Turn on the Bluetooth in the smart device (please do not pair your device Bluetooth to uPyxis, the app will do the pairing). Open the uPyxis app in the device. Swipe down to refresh the screen to scan the available Pyxis Bluetooth devices. The discovered devices will be listed as shown in *Figure 6*.

Tap the discovered ST-765SS sensor to connect to the sensor. The uPyxis app can identify the sensor type if multiple Pyxis sensors are discovered in the scan.

As shown in *Figure 6*, in the calibration page of uPyxis after connected to the sensor via the MA-CR Bluetooth adapter the current Sulfite, pH and temperature values will be displayed. Six functional tabs of each are available in this page: Zero Calibration, Slope Calibration, pH Low Calibration, pH 7 Calibration, pH High calibration and 4-20mA Span.

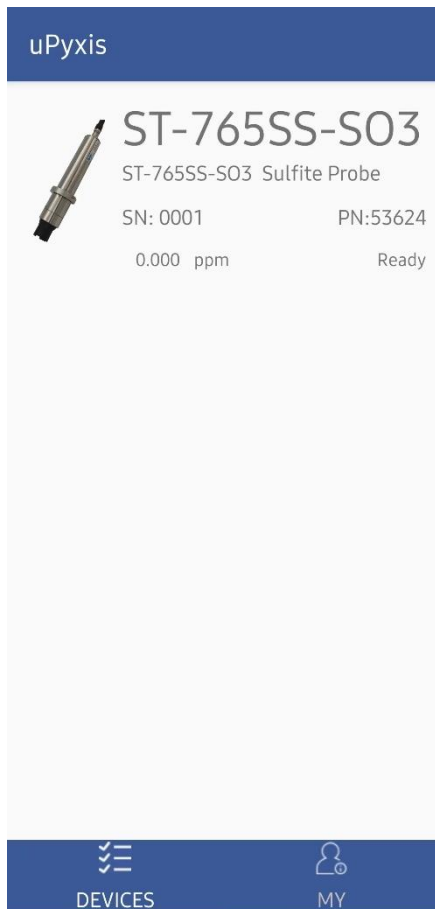

Figure 5 - ST-765SS discovered by Bluetooth scan

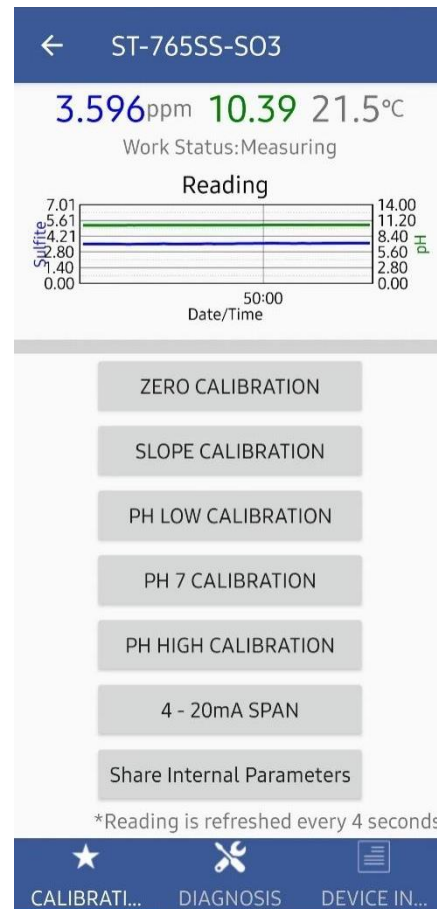

Figure 6 - Calibration Page

4.1.1 Sulfite Calibration

The measurement module of the ST-765SS-SO3 sensor is thoroughly calibrated at the Pyxis Lab factory using an Argon saturated water sample containing a precise residual concentration of Sulfite. To field calibrate the ST-765SS-SO3 sensor, the user can perform a single-point according to the requirements of the application.

Calibration of the ST-765SS-SO3 sensor for Sulfite should be done with the sensor inline exposed to active flowing sample water. Use titration method, colorimeter or fluorometer (i.e.. Pyxis SP-800 / SP-910 or Hach DR1300) to test the active (flowing) water sample in the flow tee assembly. Once you have tested and confirmed the Sulfite concentration value in the active (flowing) flow tee assembly, Tap **SLOPE CALIBRATION** and enter the test result value of the portable or laboratory colorimeter in Calibration Screen as shown in Figure 7. ***NOTE*** For best results, the concentration of the Sulfite sample flow standard should be in the range of the sensor 4-20mA output setup for the actual application.

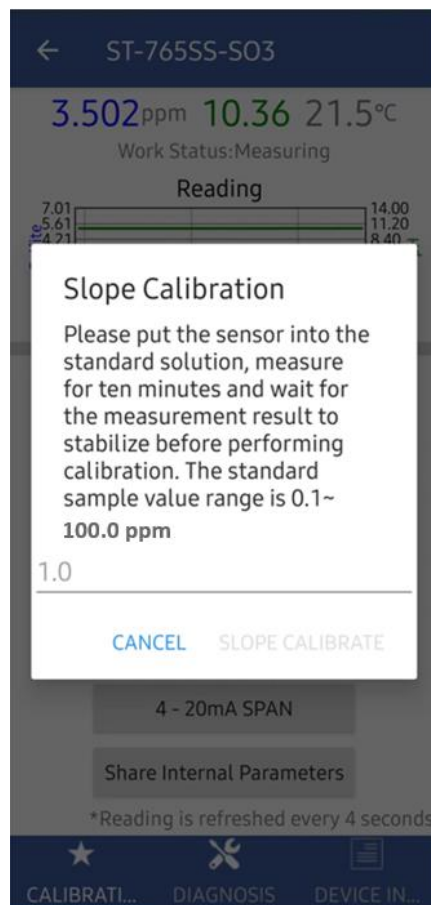

Figure 7 - Enter Sulfite concentration to begin slope calibration

4.1.2 pH Calibration

Remove and place the sensor in a low pH (i.e.. 4.0) calibration standard solution and tap **pH LOW CALIBRATION** in the uPyxis app. Measure for 1 minute and wait for the measurement result to stabilize before performing calibration, the low pH calibration standard value range acceptable for this step is 1.00-6.00 pH.

Place the sensor into the pH 7.0 calibration standard solution and tap **pH 7 CALIBRATION** in the uPyxis app. Measure for 1 minute and wait for the measurement result to stabilize before performing calibration.

Place the sensor in a high pH (i.e.. 10.0) calibration standard solution and tap **pH HIGH CALIBRATION** in the uPyxis app. Measure for 1 minute and wait for the measurement result to stabilize before performing calibration, the high pH calibration standard value range acceptable for this step is 8.00-13.00 pH.

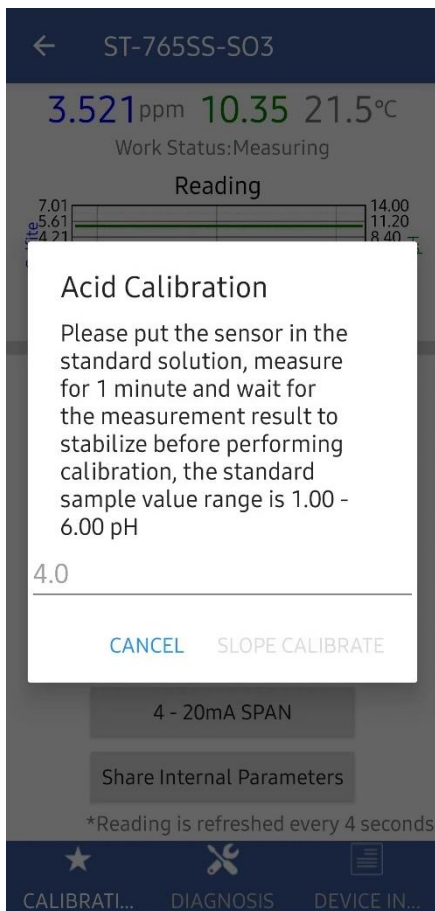

Figure 8
Enter Low-pH Concentration for Calibration

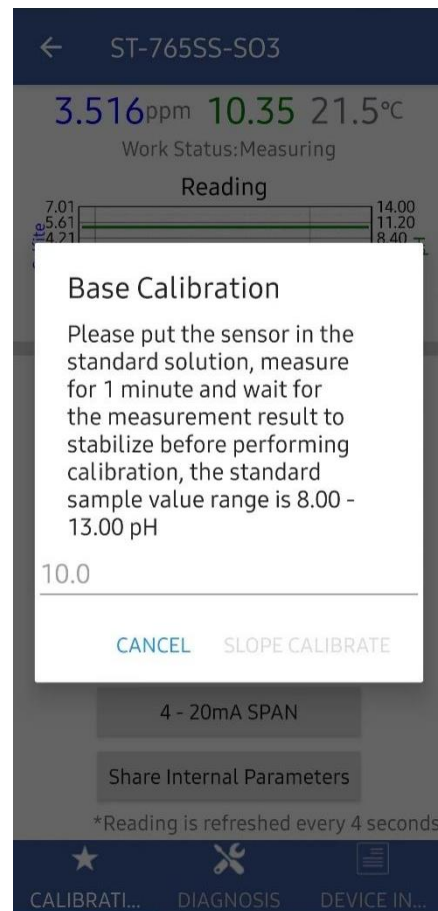

Figure 9
Enter High-pH Concentration for Calibration

4.1.3 4-20mA Span

The 4–20mA output of the ST-765SS-SO3 sensor is scaled as:

- Sulfite:
 - 4 mA = 0 ppm
 - 20 mA = 5 ppm

Tap **4-20mA SPAN** to change the Sulfite value corresponding to the 20mA output to a value below 100ppm as seen in *Figure 9*. ***NOTE*** *The 4-20mA Span feature allows users to ADJUST the 20mA output scale to a maximum value of 100ppm. You cannot INCREASE the upper limit of the sensor beyond the maximum range of the sensor (100ppm).*

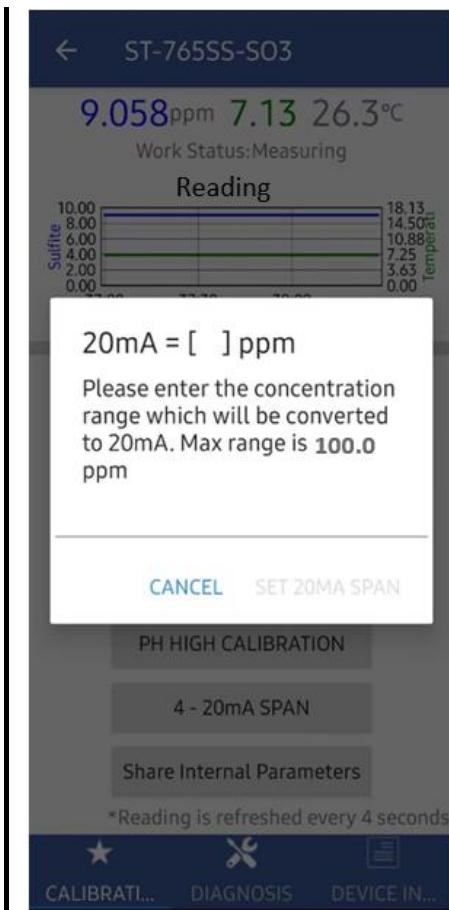

Figure 10 - Enter Sulfite concentration to set 4-20mA

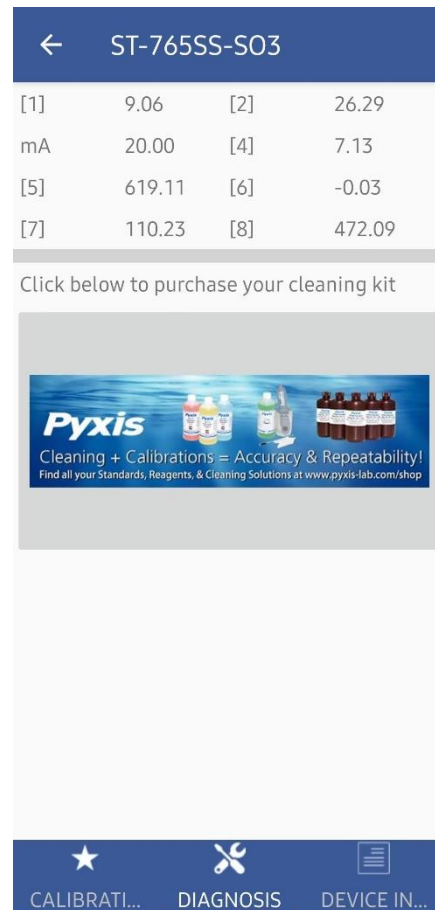

Figure 11 - Diagnostic interface

4.1.4 Diagnosis

Tap **Diagnosis** in the bottom of the app page to launch the diagnosis page *Figure 11*.

In this page, the raw data measured by the sensor is displayed. To help troubleshooting possible issues with the sensor, please save images of these data when the sensor is respectively placed in a clean water (tap water or deionized water), in a Sulfite, or pH standard solution, and in the sample that the sensor is intended for. This data may be exported from the uPyxis APP via email to service@pyxis-lab.com for technical support.

4.2 Calibration and Diagnosis by uPyxis Desktop App

1) Download and install uPyxis Desktop APP from

<https://upyxis.pyxis-lab.com.cn/release/pc/uPyxis.Setup-latest.zip>

2) Connect a USB Type-C cable to the port at the bottom of the MA-CR and to the USB port of the laptop or computer. This will provide power the MA-CR from the laptop/computer. Connect the MA-CR to the ST-765SS-O3 sensor. The MA-CR Bluetooth adapter will boost the 5V of the regular USB to 24V to power the sensor for use with uPyxis Desktop.



MA-CR Bluetooth Adapter – Bottom USB-C

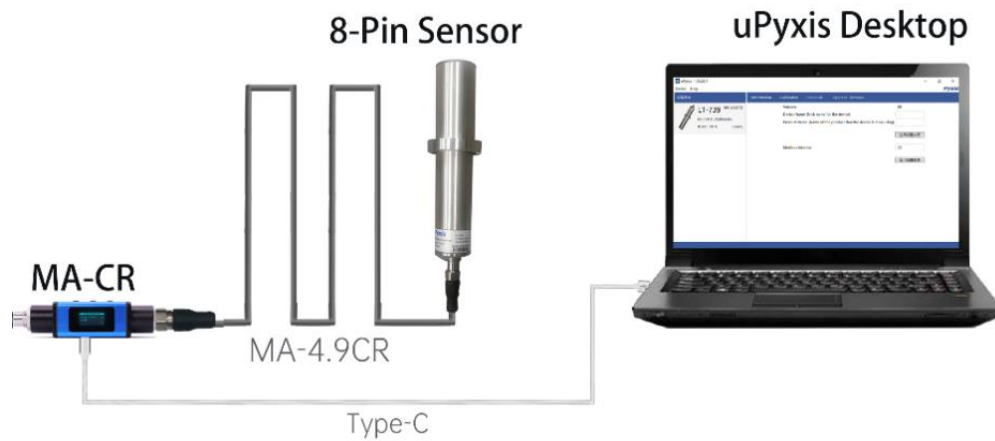

Figure 12 – MA-CR Connected to Sensor & Laptop

3) Set the MA-CR to operate in USB Mode by following the steps below.

- a. Once the MA-CR screen is powered Press ◀ or ▶ until you arrive at (USB to RS485) screen.
- b. Press the **OK** Button.
- c. Follow Prompts below to Enable USB feature. Once enabled, you may connect to uPyxis.



- 4) Open the desktop uPyxis APP.
- 5) Click Device to launch the connection option menu.
- 6) Select Connect via USB-RS485 (*Figure 13*).
- 7) Select the Comm Port to make a connection. Normally only one Comm port is identified by uPyxis (*Figure 14*). If more than one Comm port listed in the selection dropdown, you may try to select each one to see if a connection can be made. Alternatively, you may use the Windows Device Manager to identify the Comm Port that the Pyxis USB adapter is using.

After the connection is established, the ST-765SS sensor series number and Ozone reading will be displayed on the left of the information page *Figure 15*. In this page, a nickname can be assigned to the sensor. The sensor Modbus address can also be changed if desired. Click Calibration to launch the calibration page *Figure 16*.

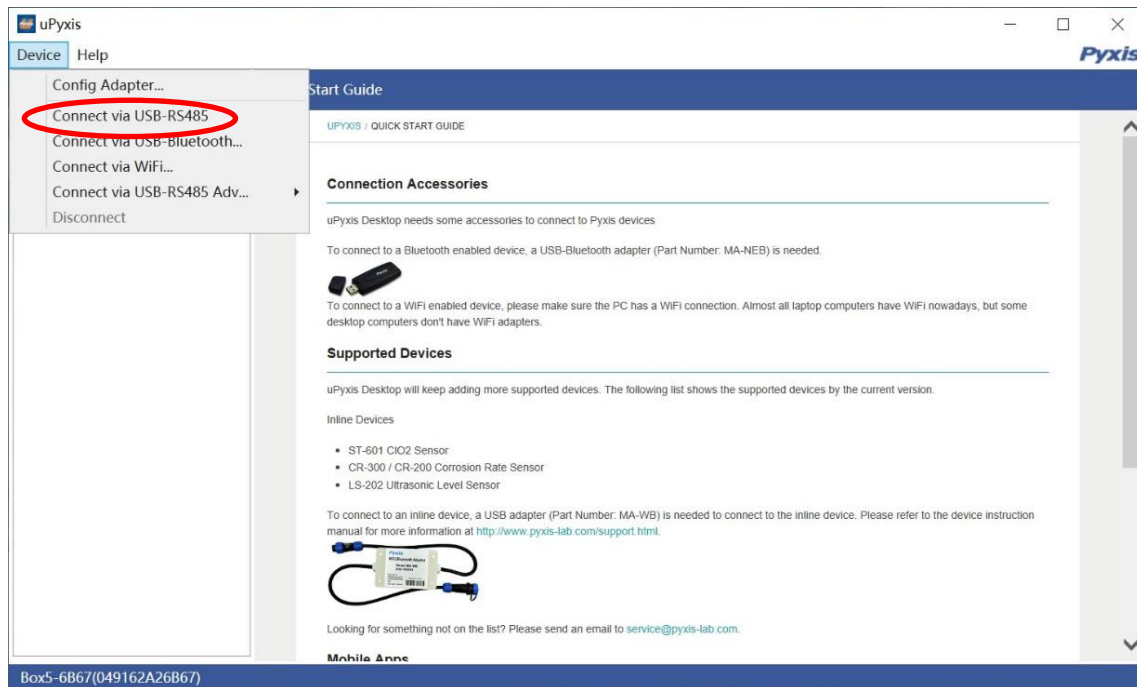

Figure 13 - Connection Options

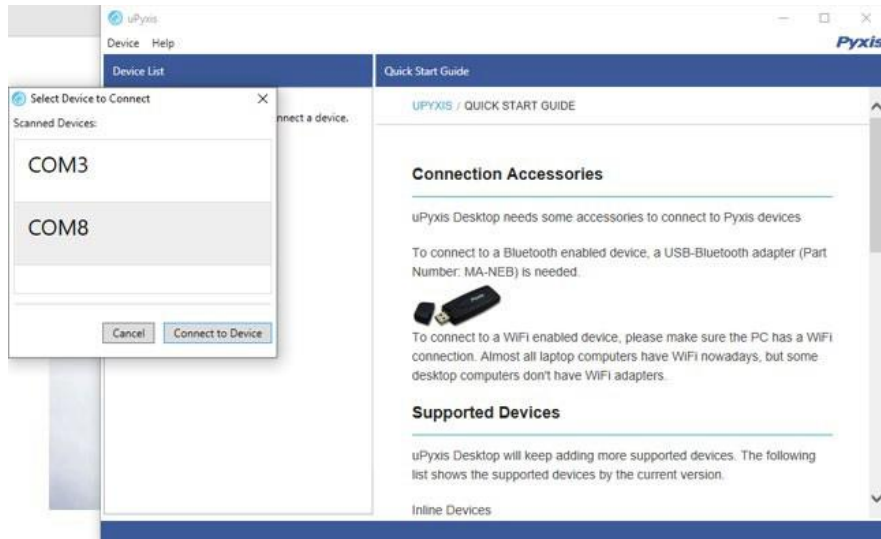

Figure 14 - Select a Comm port

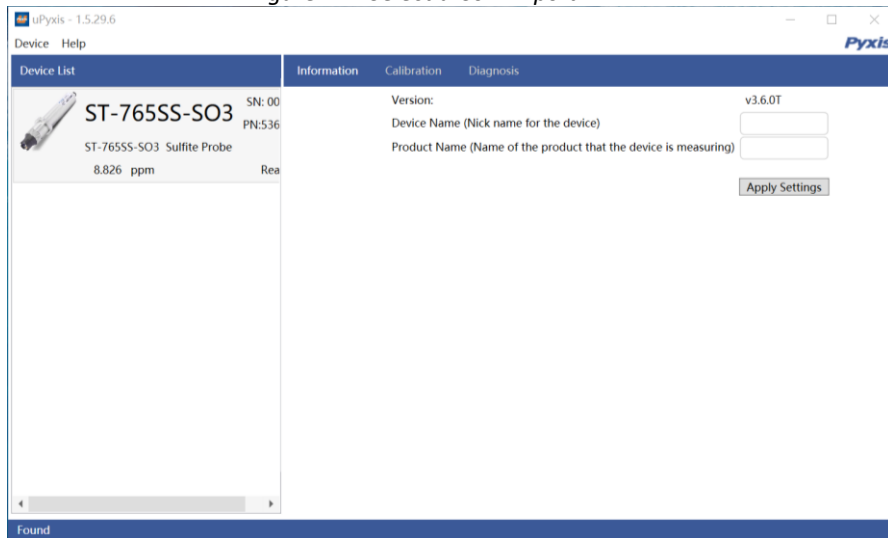

Figure 15 - Connected to a ST-765SS sensor and information page

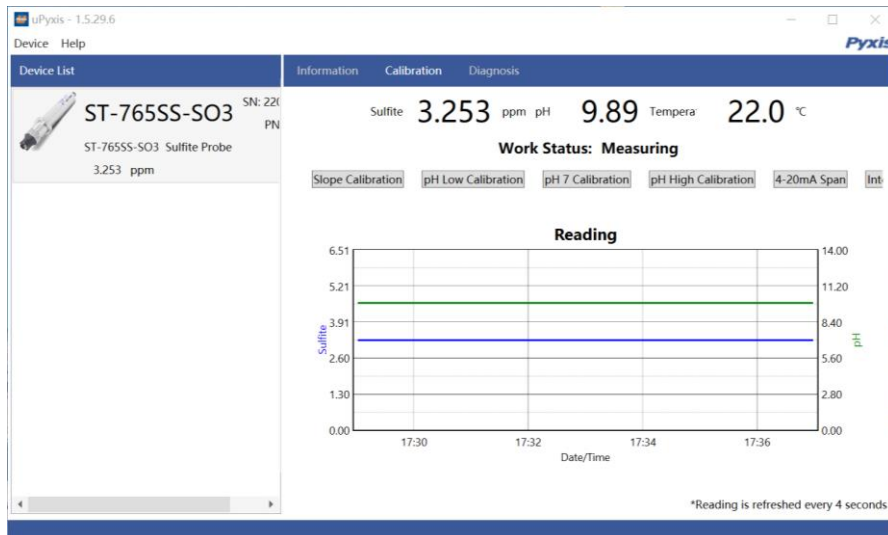

Figure 16 - Calibration Page

4.2.1 Sulfite Calibration

The measurement module of the ST-765SS-SO3 sensor is thoroughly calibrated at the Pyxis Lab factory. To calibrate, the user can perform a single-point according to the requirements of the application.

Calibration of the ST-765SS-SO3 sensor for Sulfite should be done with the sensor inline exposed to active flowing sample water. Use a portable or laboratory colorimeter (i.e.. Pyxis SP-200 / SP-800 / SP-910 or similar) to test the active (flowing) water sample in the flow tee assembly. Once you have tested and confirmed the concentration value in the active (flowing) flow tee assembly, Tap **SLOPE CALIBRATION** and enter the test result value of the portable or laboratory colorimeter in Calibration Screen as shown in Figure 17. ***NOTE*** For best results, the concentration of the Sulfite sample flow standard should be in the range of the sensor 4-20mA output setup for the actual application.

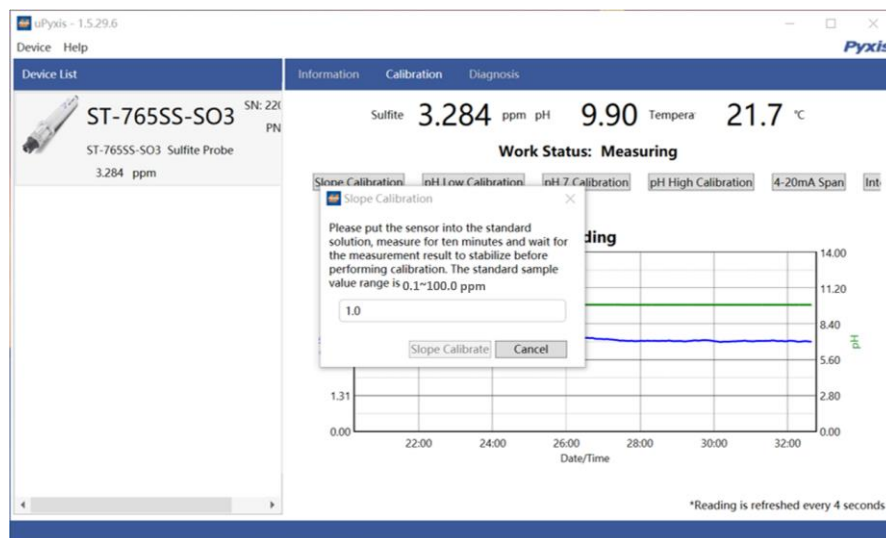

Figure 17 - Slope Calibration

4.2.2 pH Calibration

Remove and place the sensor in a low pH (i.e.. 4.0) calibration standard solution and tap **pH LOW CALIBRATION** in the uPyxis app. Measure for 1 minute and wait for the measurement result to stabilize before performing calibration, the low pH calibration standard value range acceptable for this step is 1.00-6.00 pH.

Place the sensor into the pH 7.0 calibration standard solution and tap **pH 7 CALIBRATION** in the uPyxis app. Measure for 1 minute and wait for the measurement result to stabilize before performing calibration. Place the sensor in a high pH (i.e.. 10.0) calibration standard solution and tap **pH HIGH CALIBRATION** in the uPyxis app. Measure for 1 minute and wait for the measurement result to stabilize before performing calibration, the high pH calibration standard value range acceptable for this step is 8.00-13.00 pH.

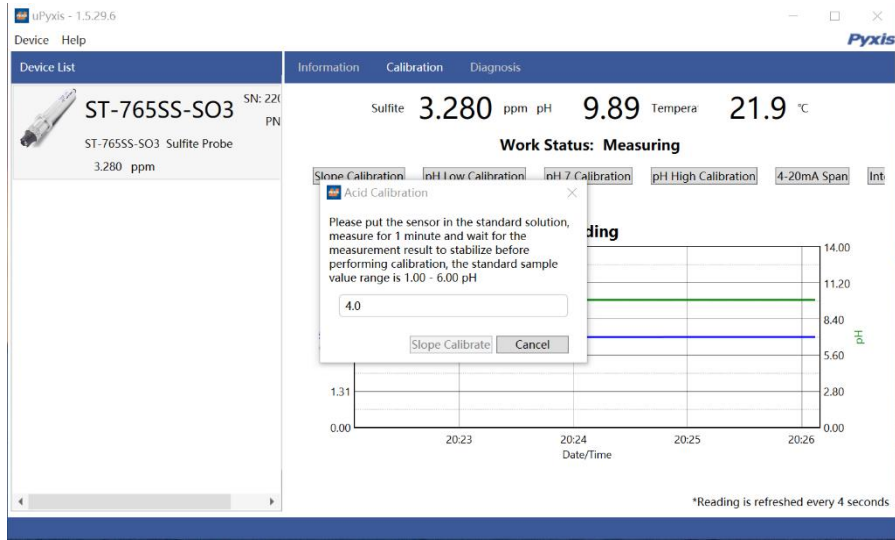

Figure 18 - pH Low Calibration

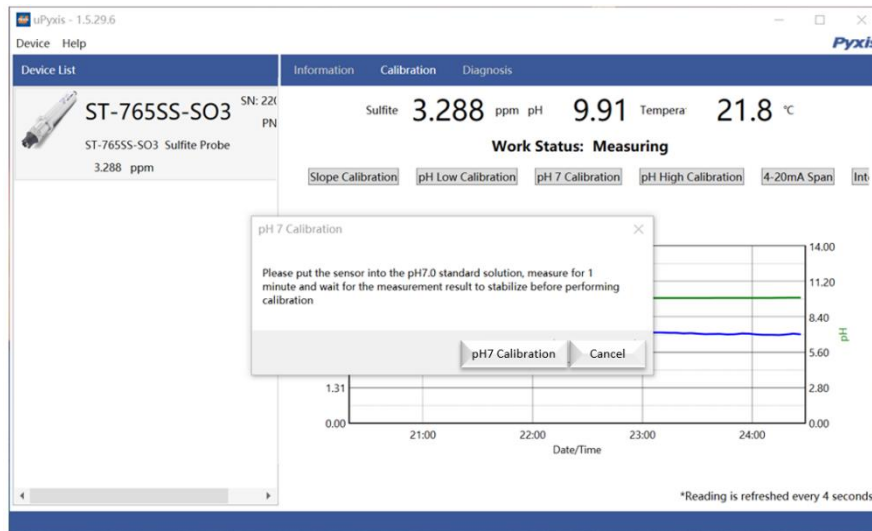

Figure 19 - pH 7 Calibration

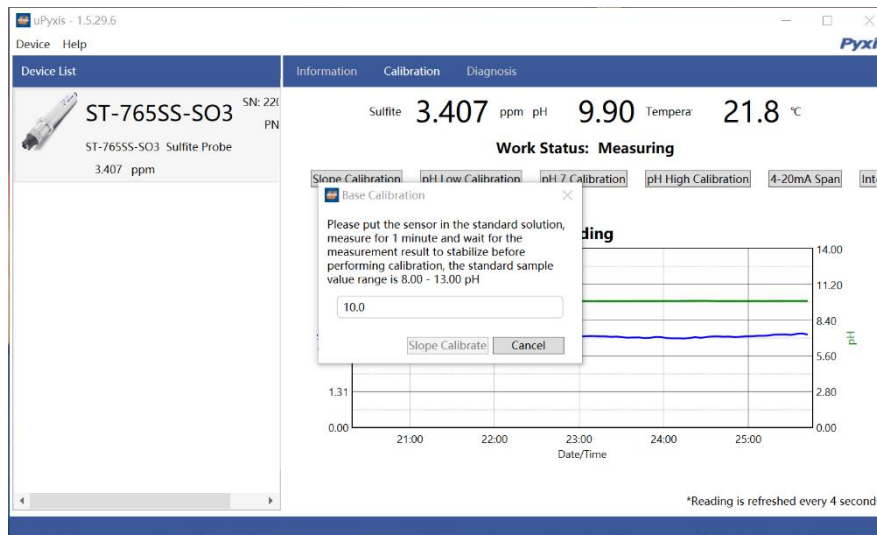

Figure 20 - pH High Calibration

4.2.3 4-20mA Span

The 4–20mA output of the ST-765SS-SO3 sensor is scaled as:

- Sulfite:
 - 4 mA = 0 ppm
 - 20 mA = 5 ppm

Tap **4-20mA SPAN** to change the Sulfite value corresponding to the 20mA output to a value below 100ppm as seen in Figure 21. ***NOTE*** The 4-20mA Span feature allows users to ADJUST the 20mA output scale to a maximum value of 100ppm. You cannot INCREASE the upper limit of the sensor beyond the maximum range of the sensor (100ppm).

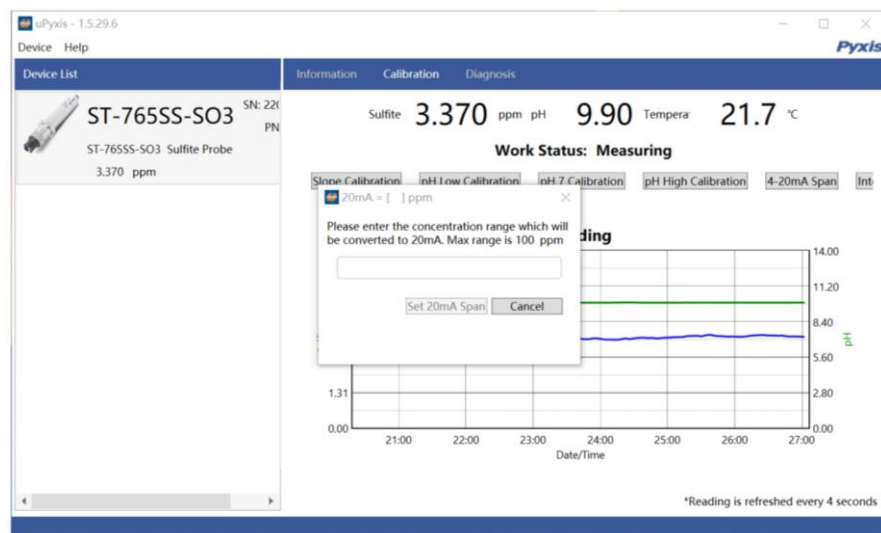

Figure 21 - set 4-20mA span

4.2.4 Diagnosis

Tap **Diagnosis** in the bottom of the app page to launch the diagnosis page *Figure 22*. In this page, the raw data measured by the sensor is displayed. To help troubleshooting possible issues with the sensor, please save images of these data when the sensor is respectively placed in a clean water (tap water or deionized water), in a Sulfite or pH standard solution, and in the sample that the sensor is intended for. This data may be exported from the uPyxis APP via email to service@pyxis-lab.com for technical support.

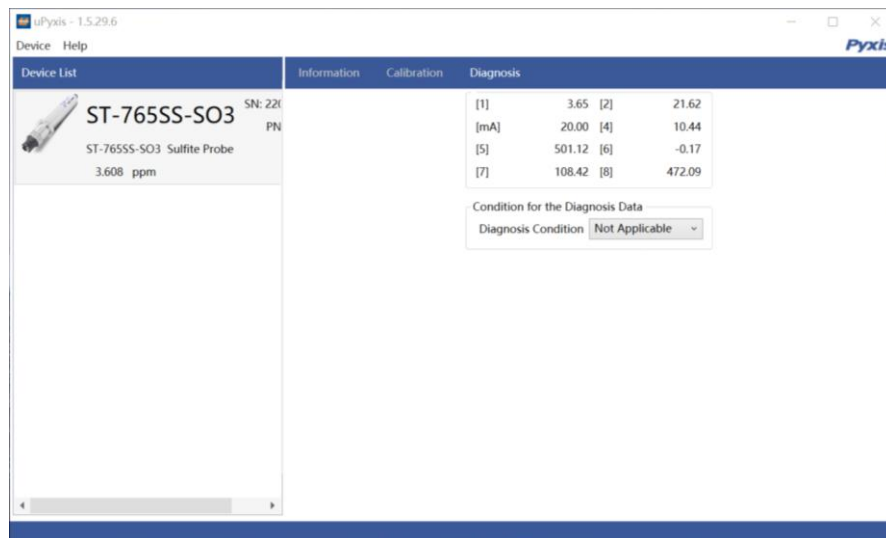

Figure 22 - Diagnostic Interface

5. Calibration on the Controller

It is recommended that the ST-765SS Series calibration be carried out using the uPyxis app as demonstrated in the sections above. Alternatively, a single point calibration can be carried on the controller by adjusting the mA-to-ppm ratio (Sulfite). However, if calibration is to be performed via the controller, it must be cleaned with deionized water prior to calibration, taking care to avoid direct hand contact with the electrodes. Please follow the controller manufacturer's procedures for 4-20mA calibration as with any sensor. With the default sensor settings, the controller should be set to convert 4 mA to 0 ppm and 20 mA to 5.00 ppm for ST-765SS-SO3.

Calibration of the ST-765SS-SO3 sensor for Sulfite should be done with the sensor inline exposed to active flowing sample water. Use titration method, colorimeter or fluorometer (i.e.. Pyxis SP-800 / SP-910 or Hach DR-1300) to test the active (flowing) water sample in the flow tee assembly of the IK-765SS-SO3 panel.

6. Modbus RTU

The ST-765SS-SO3 Series sensors are configured as a Modbus slave device. In addition to the ppm Sulfite, many operational parameters, including warning and error messages, are available via a Modbus RTU connection. Contact Pyxis Lab Customer Service (service@pyxis-lab.com) for more information.

7. Sensor Cleaning and Maintenance

Soak the lower half of the sensor in 100 mL inline sensor cleaning solution for 10-15 minutes. Gently rub the sensor electrode head with the provided Q-tips. If the surface is not entirely clean, continue to soak the sensor for an additional time until clean. Rinse the sensor with distilled water. Pyxis Lab Inline Sensor Cleaning Solution can be purchased at our online Estore/Catalog at <https://www.pyxis-lab.com/product/inline-sensor-cleaning-kit/>



Figure 23 - ST-Series Probe Cleaning Kit
(P/N SER-01)

7.1 Other Common Troubleshooting Issues

If the ST-765SS sensor output signal is not stable and fluctuates significantly, make an additional solution ground connection—connect the black ground wire to a conductor that contacts the sample water electrically such as a brass pipe adjacent to the ST-765SS.

8. Replacing pH and Reducer Electrode Head

The pH/oxidizer electrode head of ST-765SS Series can be replaced when the original electrode head reaches its working life. The typical working life of the electrode can be as long as 2-years under normal operating conditions. Order a replacement electrode head EH-765 (P/N 53061) from Pyxis and follow instructions as below.

Order a replacement electrode head EH-765 (P/N 53061) from Pyxis and follow instructions as below.

1. Turn off the sensor if it is powered on.
2. Make sure there is no water on the sensor.
3. Hold the ST-765SS main body with one hand and use the other hand to twist the stainless-steel locking ring counter-clockwise until the front end of the black electrode is completely unscrewed, as shown in *Figure 24-2*
4. Pull out the electrode head as shown in *Figure 24-3*.
5. Loosen the electrode plug connector, and remove the electrode head, as show in *Figure 24-4*.
6. To assemble the new electrode head, connect the plug, then insert the new electrode head into the main sensor housing and ensure that the two protrusions on the electrode head are aligned with the notches in the sensor main housing.
7. Then twist the stainless-steel lock ring of ST-765SS in a clockwise direction until the threads of the electrode head completely enter the ST-765SS housing as shown in *Figure 24-1*.

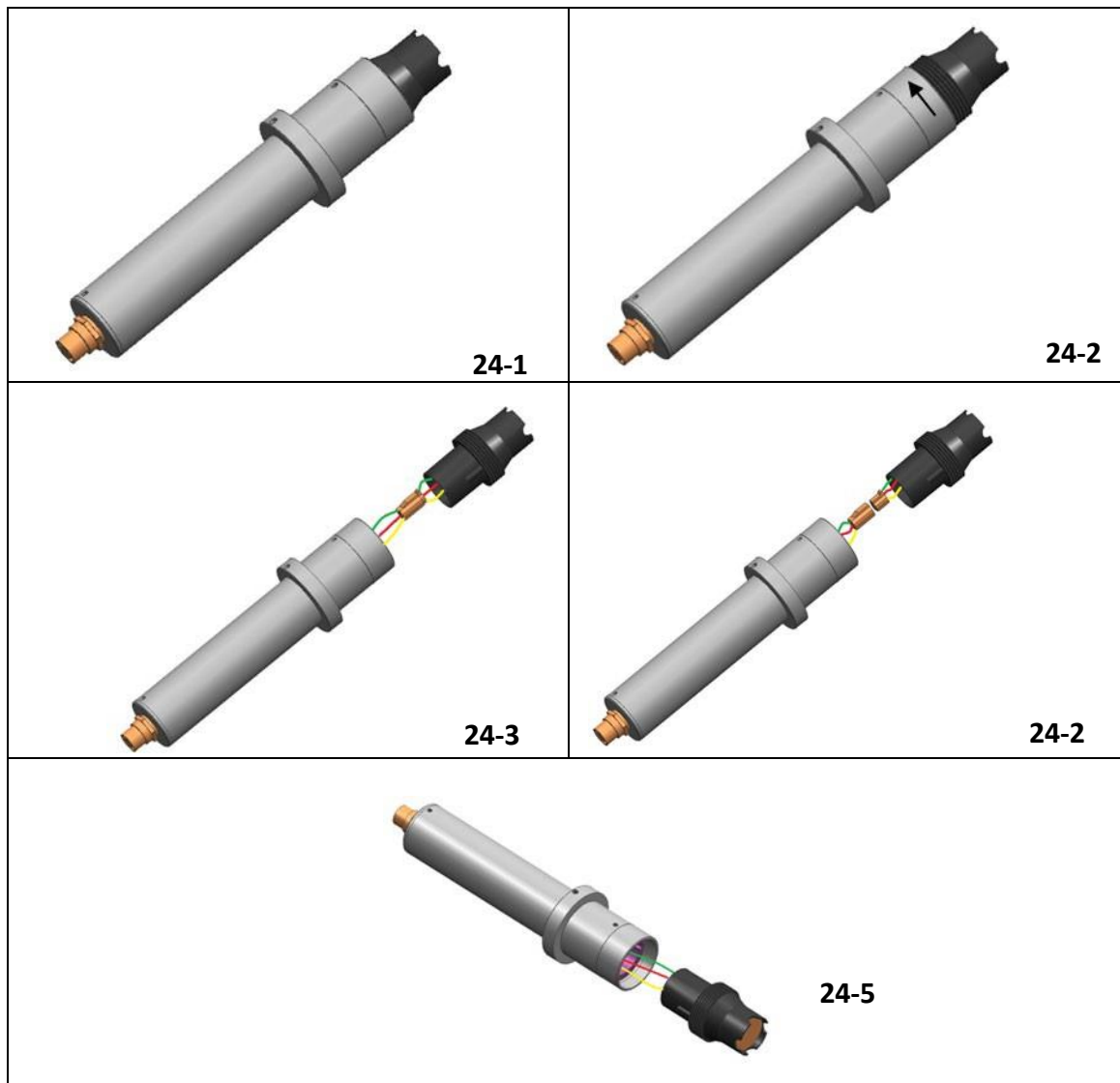

9. Contact Us

Pyxis Lab, Inc

1729 Majestic Dr. Suite 5

Lafayette, CO 80026 USA

www.pyxis-lab.com

Phone: +1 (866) 203-8397

Email: service@pyxis-lab.com